

## Capítulo 5 (Milo)

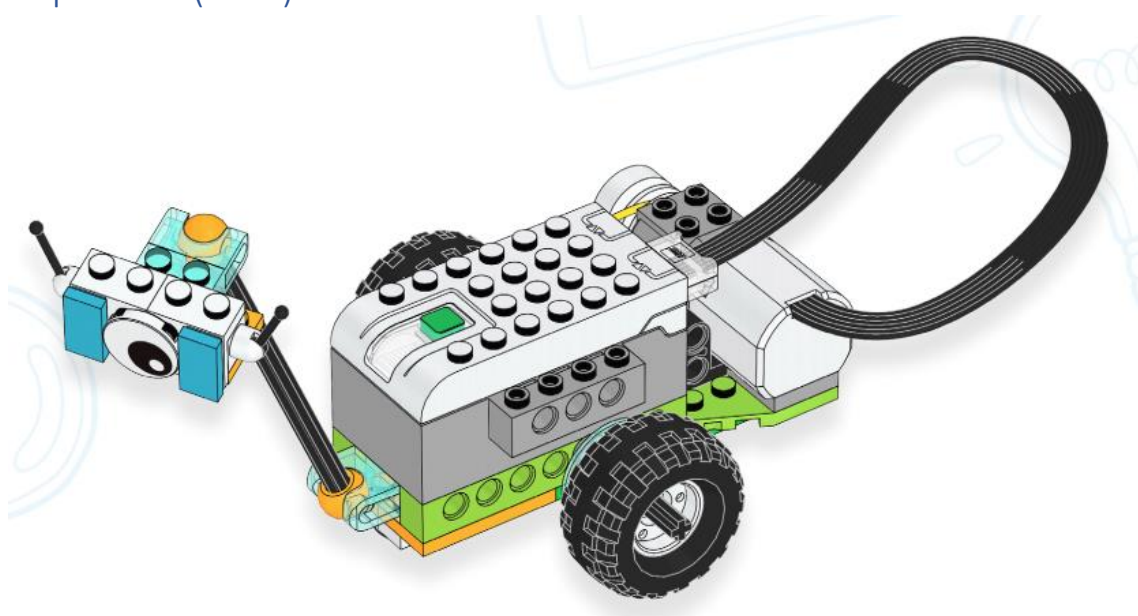

### **ADVERTENCIA:** **PELIGRO DE ASFIXIA.**

Juguete que contiene partes pequeñas y una pelota pequeña. No recomendado para niños menores de 3 años.



Este capítulo se puede realizar con un kit.

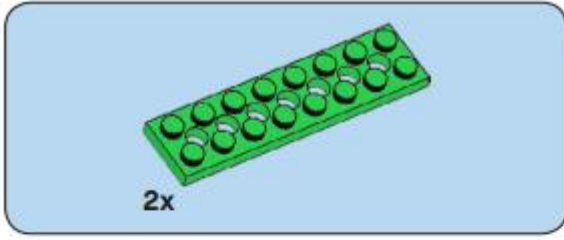

**1**

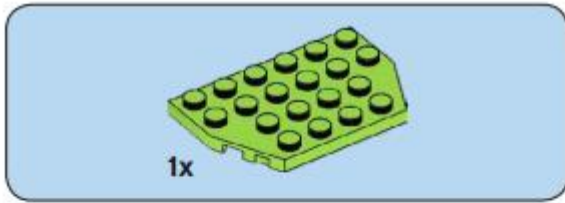
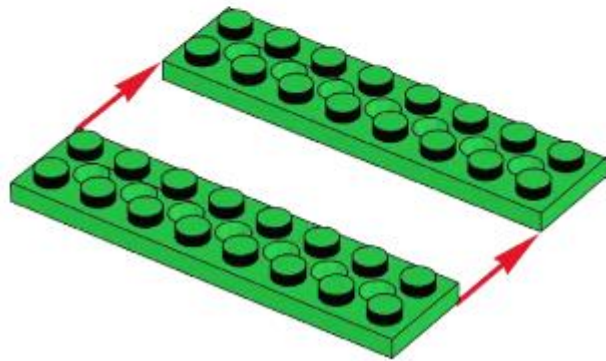

**2**

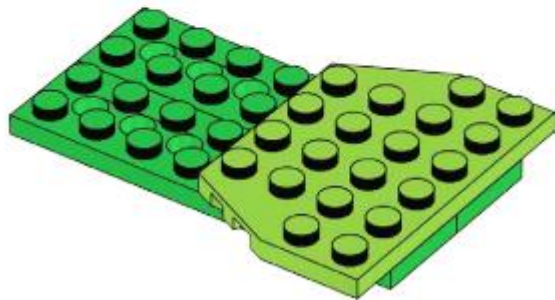



3

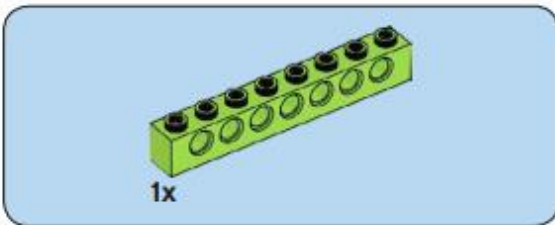
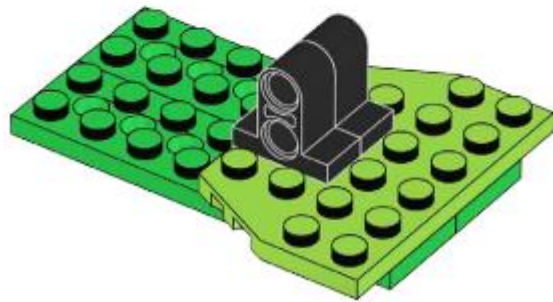

4

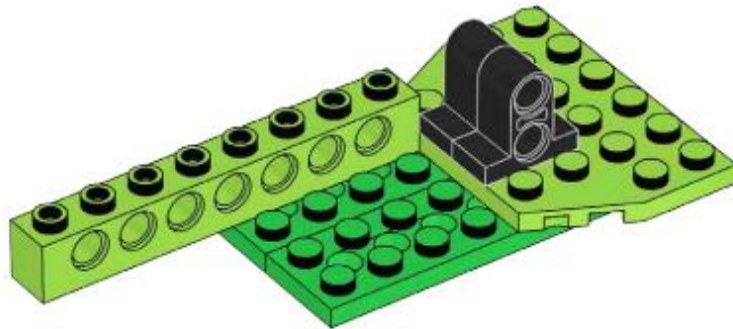

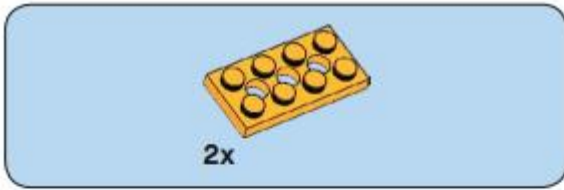

5

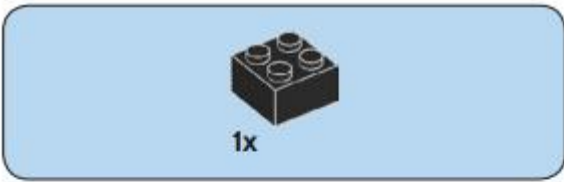
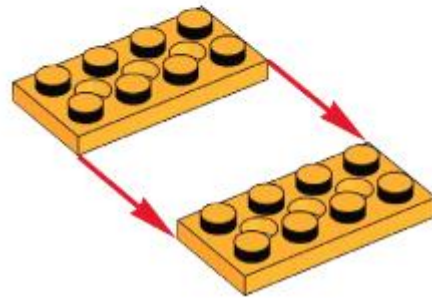

6

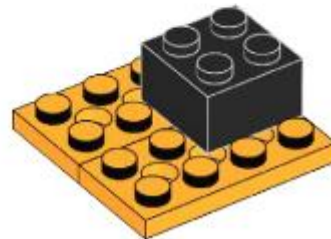

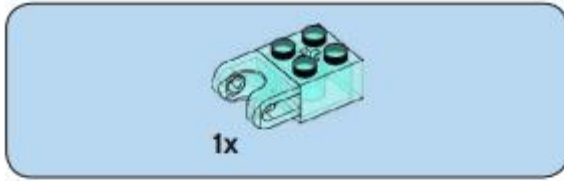

7

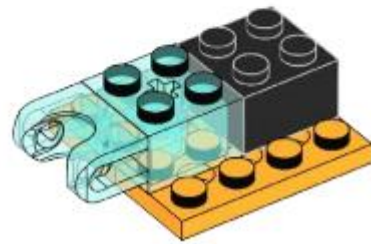

8

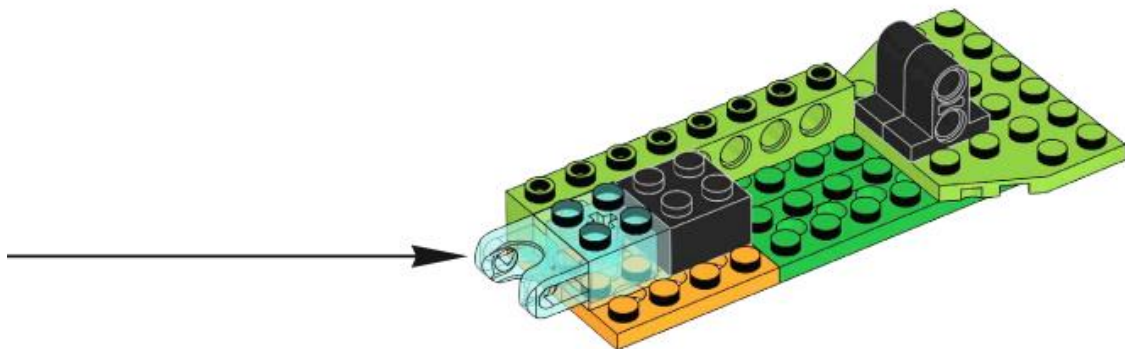

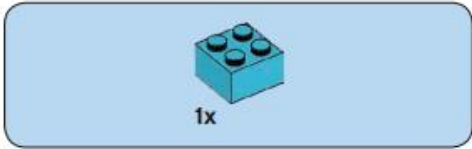

9

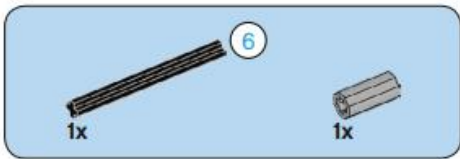
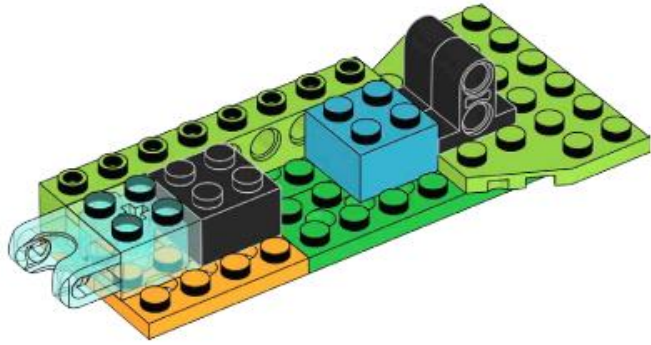

10

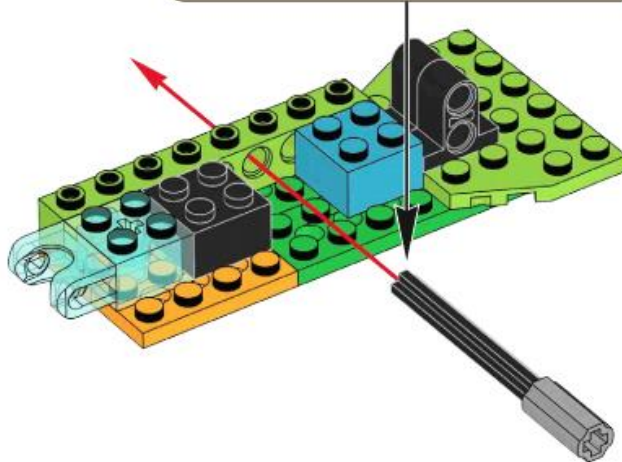
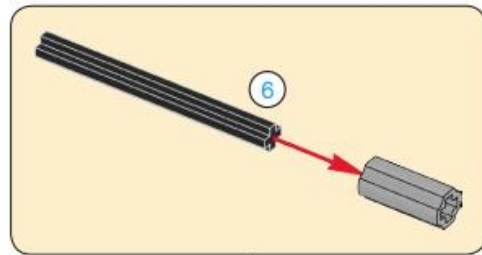

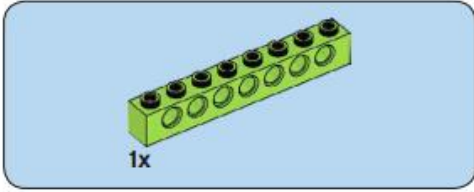

11

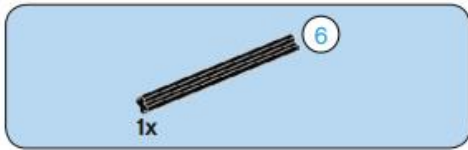
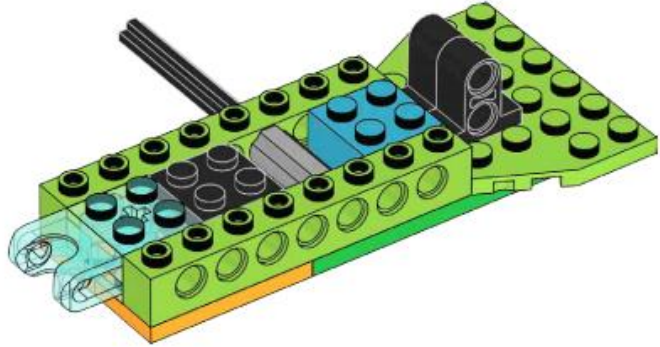

12

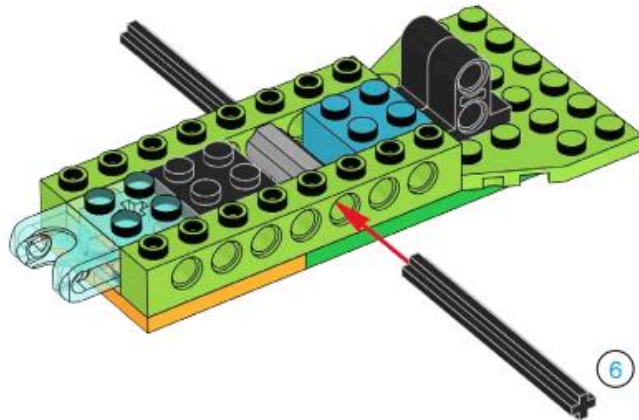

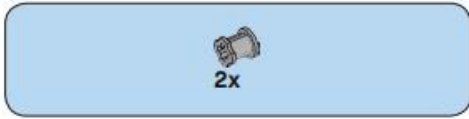

13

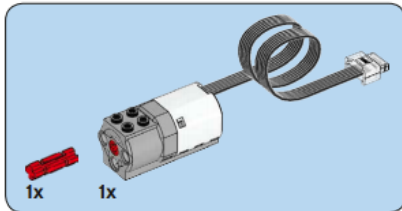
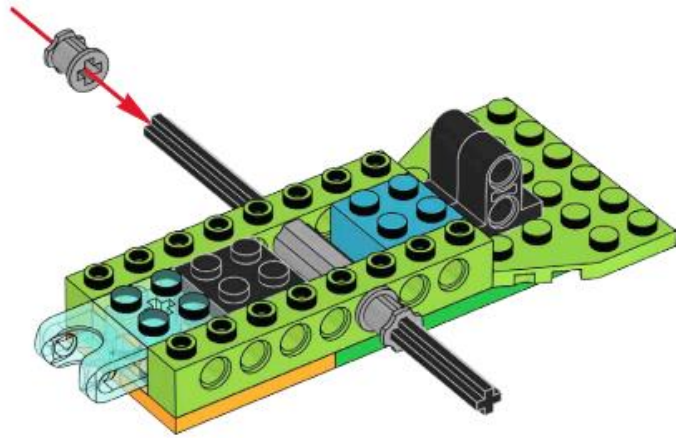

14

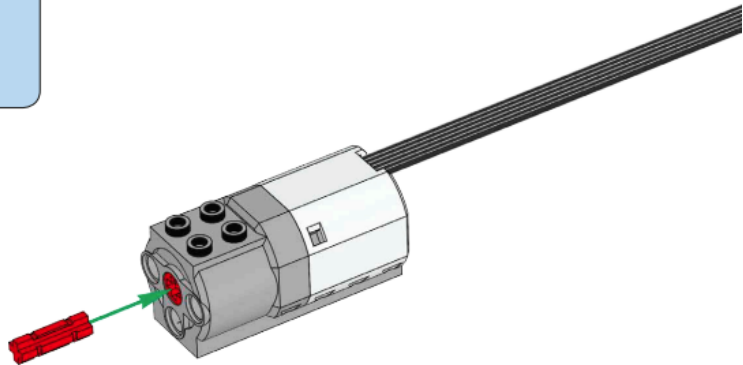



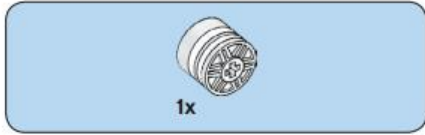

15

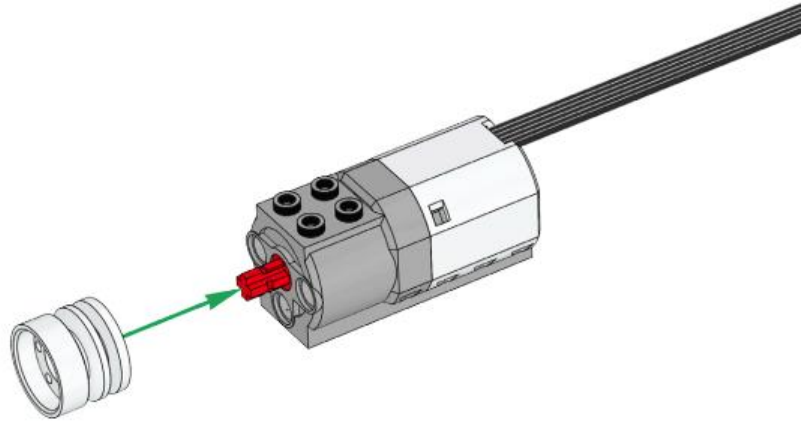

16

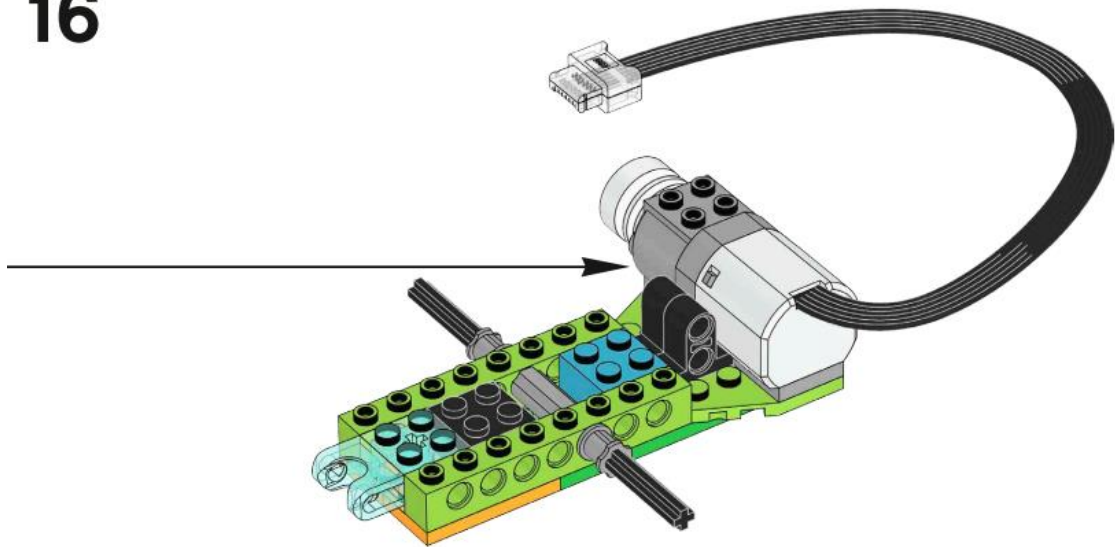

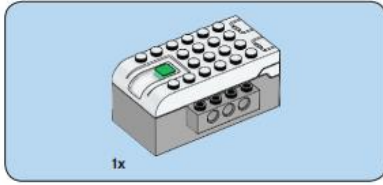

17

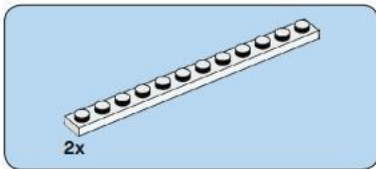
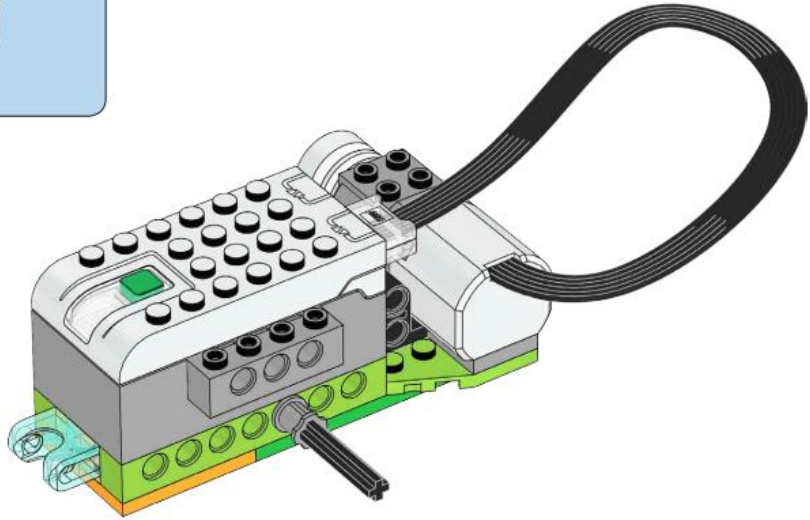

18

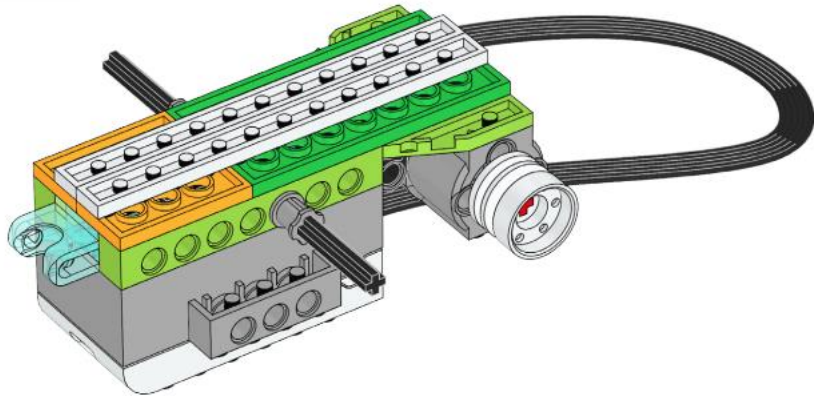



19

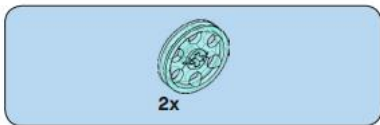
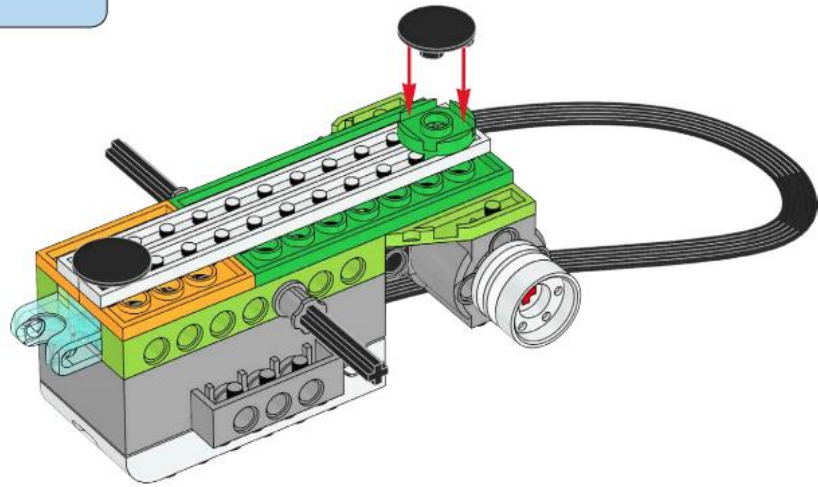

20

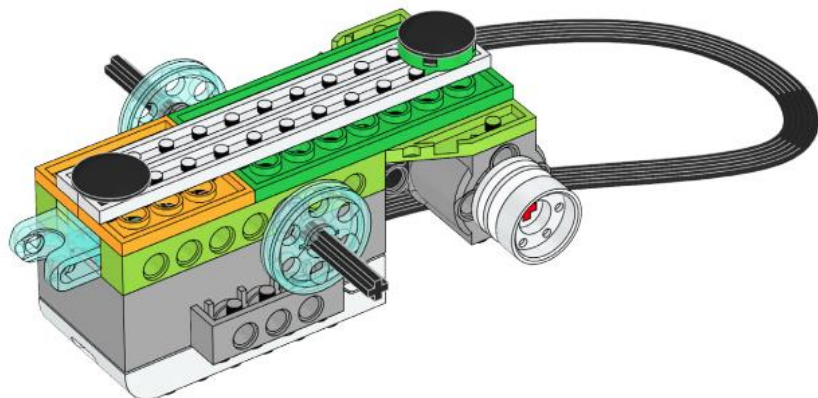

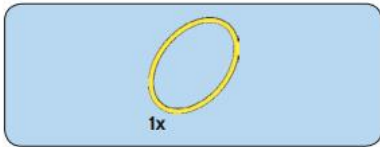

21

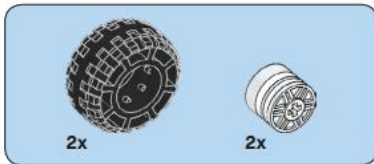
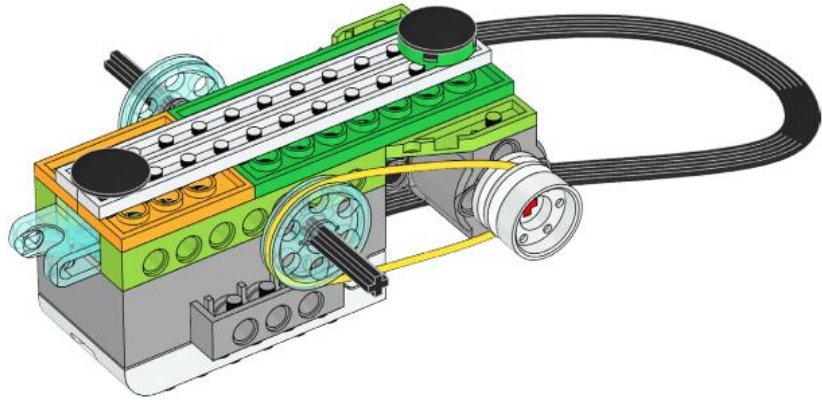

22

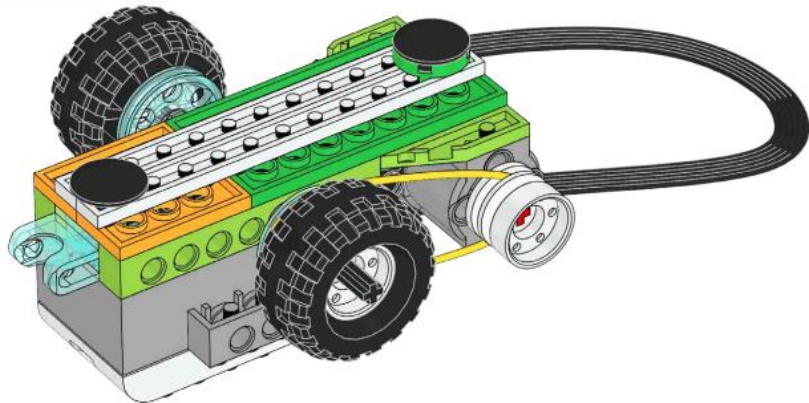

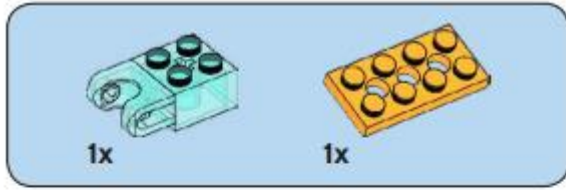

**23**

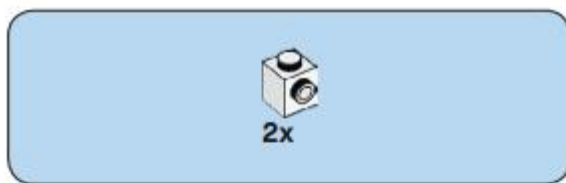
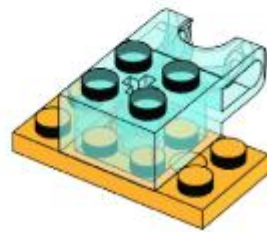

**24**

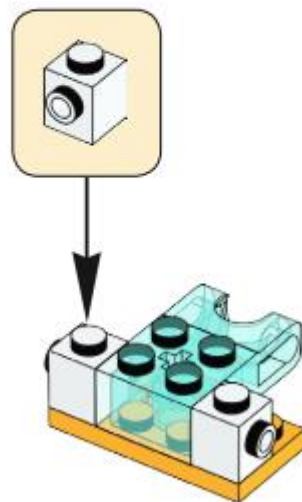

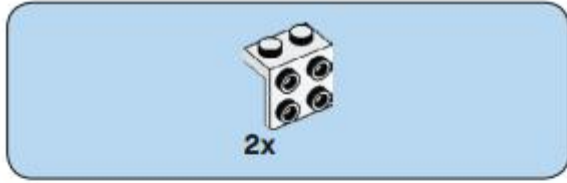

**25**

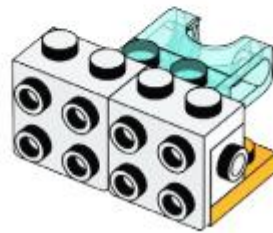

**26**

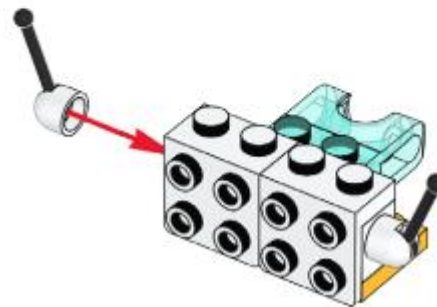

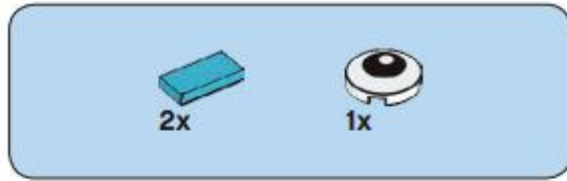

27

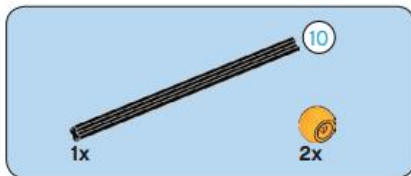

28

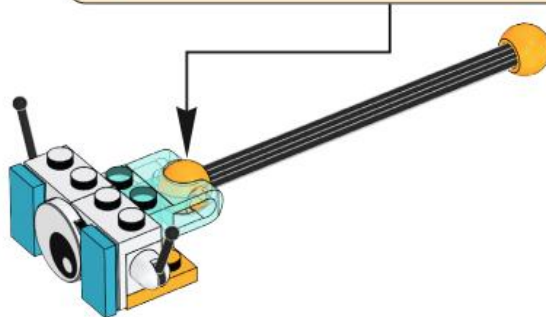
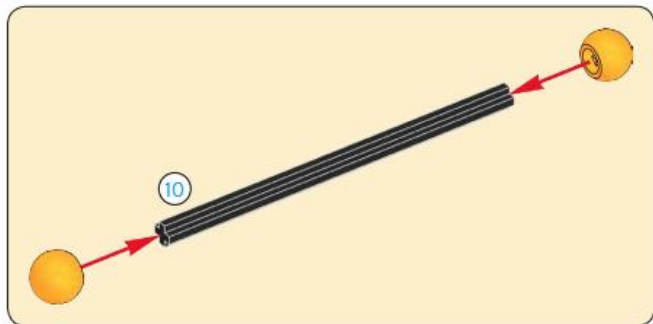

# 29

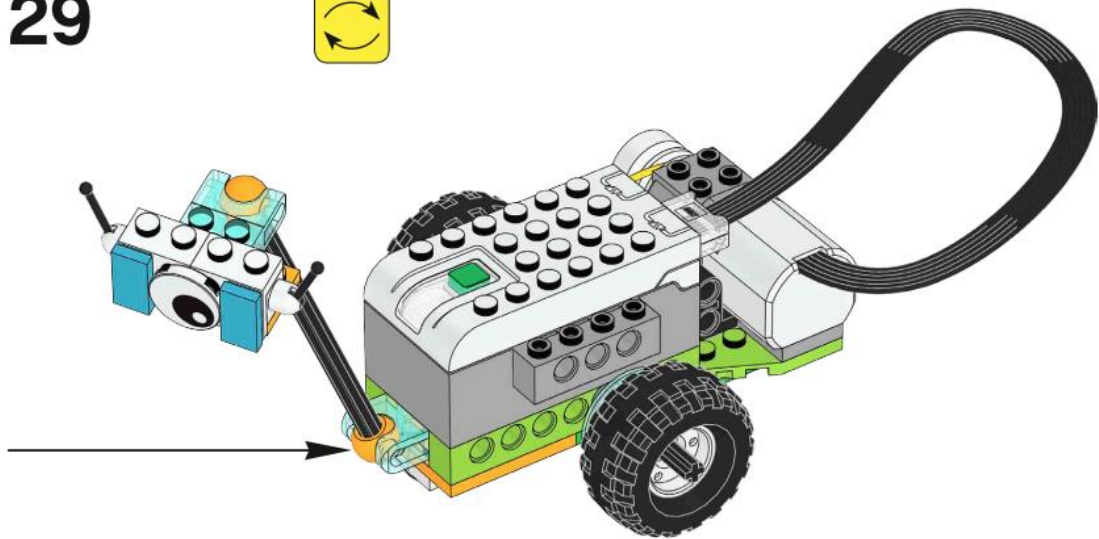

## Codificación

En este primer programa vamos a realizar que nuestro robot se adelante unos centímetros de detenga y luego retroceda los mismos centímetros.

Potencia de 30

Giro dirección agujas del reloj.

Recorrido durante 2 segundos y parar.

Esperar 1 segundo.

Giro dirección contraria a las agujas del reloj.

Recorrido durante 2 segundos y parar.

